

## Position Paper, PP – 2014-07-09

Contact person  
Morten Schmelzer

Phone  
+32 (0)471 71 52 61

Email  
morten.schmelzer@eurovent-association.eu

Date  
2014-07-09

### Extended Eurovent Position on 'Fan Definitions' & the Regulation Scope

In its first Position on the Revision of the 'EU Fan Regulation' 327/2011 (find attached to this PDF file), Eurovent asked VHK and the European Commission to 'provide clear definitions and clarify what exactly is in the scope of the measure'. It was stated that...

Products within the scope shall be measureable and it should be possible to survey these products. Today, this is not possible for impellers alone. The interpretation made in the FAQ document to Regulation 327/2011 is not substantiated by any kind of arguments. Eurovent strongly advises legislators to exclude impellers from the legislation.

In the following, Eurovent provides for an extended version of this position in the hope that regulators are going to acknowledge the loopholes that would maintain from non-action on this issue.

#### Extended Position

The placement on the market of a fan, stand-alone or integrated in another energy relevant product, happens when a final assembly is either sold to the final user, or put in operation. Then a declaration of conformity (DOC) must be issued. At that time, an impeller must have been combined with a motor and a case.

Eurovent strongly believes that there is no need to have impellers within the scope of the Regulation if the complete assembly must be covered by the DOC. At the time of issuing the DOC, the motors chosen to drive the fan must be known and, as a consequence, actual experimental data on the motor efficiency should preferably be used to compute the efficiency of the complete fan rather than minimum standard efficiencies.

As the missing parts do have a significant impact on the efficiency of the final assembly, a vast majority within Eurovent argues that it is reasonable to write a regulation which demands that...

- Complete assemblies comply with minimum efficiency requirements, once placed on the market or put in operation,
- Complete assemblies are provided with an original manufacturer's declaration (essentially similar to the MD Declaration of Incorporation), providing all the essential data which is necessary to state a Declaration of Conformity,
- Any not-complete assembly is provided, by the original manufacturer, with a similar declaration, but stating under which nominal conditions (use of specified motor or of a specified geometry of the missing essential parts) the rated efficiency data was measured and may be achieved,
- The Declaration of Conformity of the complete assemblies obtained by adding essential parts to not complete assemblies procured from other manufacturers clearly states whether the added parts are built according to the manufacturer's requirements, and consequently that
- The Declaration is based on the original manufacturer's measurements and data, or whether parts of original design have been used, and that consequently the conformity assessment was based on original data.

In addition to the mentioned position, the ANNEX to this paper also offers a position that did not find a majority within Eurovent. As Eurovent represents the entire HVAC&R sector, this allows VHK and the European Commission to also be aware of a differing position.

## Working definitions

Following an in-depth working session on this issue with heating, ventilation, air conditioning and refrigeration manufacturers as well as national association representatives present, Eurovent strongly recommends VHK and the European Commission to consider the following working definitions in order to avoid future misinterpretations and loopholes.

### A fan placed on the market, or put in operation

To be placed on the market, or put in operation, according to the latest interpretation of how these concepts apply to electrically-driven fans, a fan must be composed of at least three parts:

1. An impeller, or rotor, or wheel (roue -fr-, girante -it-, Laufrad -de-), which transfers mechanical energy to the fluid,  
i.e. some kind of bladed disk, taking energy from a rotary motion and transferring that to a fluid,
2. A stator (nozzle or case, depending on the type of fan), which conditions the flow before it interacts with the moving blades, and converts kinetic energy into pressure and this may be a simple nozzle (inlet-nozzle in the case of backward-curved fans without scroll, or containment nozzle for propeller fans) or a more complex case (scroll case of most centrifugal fans, tubular case, with or without flow straightener, for most axial fans and some centrifugal fans).
3. An electric motor (within the scope of the existing EU regulation, AC or DC mains-supplied), which provides the mechanical power to rotate the impeller.

An assembly which includes at least these three parts may be ready to convert electrical power into a continuous flow of a gas (sometimes also including liquid or solid particles in suspension), between two separate spaces, having a difference of pressure which opposes the natural flow of the fluid.

Such an assembly can be put in operation and/or tested (under standardised conditions) to measure and rate its energy efficiency.

### 'Impeller'

An 'impeller', missing the motor, but also the nozzle or case which is necessary to measure the fan performance, and the design of which impacts on the performance, and particularly on its efficiency, cannot be either tested, or rated, before being completed with the missing essential parts. These may be in accordance with the manufacturer's recommended or nominal arrangement.

### 'Not complete assemblies'

Before being put in operation, the current market structure sees the sale of different types of assemblies, which are including only some of these parts.

The following assemblies may fall in the category 'not complete assemblies':

A most commonly type known as 'bare-shaft fan'.

It is a fan complete with the impeller and case or inlet nozzle and pressure-plate (if it is a backward-curved fan without scroll) where the impeller is supported on a shaft and a pair of bearings, but the assembly is still sold without a driving motor.

It is also known as 'belt-driven fan', because it is most often connected to the driving motor, chosen and installed by an integrator, with a mechanical transmission made of pulleys and rubberised belts (although the use of an in-line coupling is gaining success, even if this arrangement introduced some additional mechanical problems).

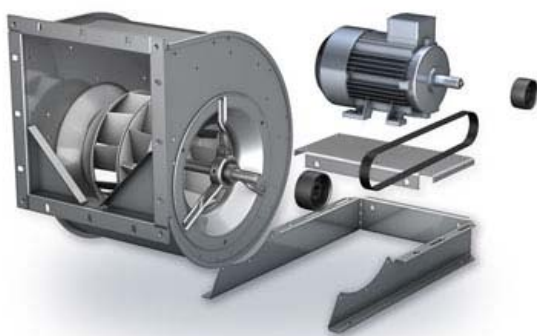

Example of a 'belt driven fan' arrangement [permission for usage granted by owner]

It is a type of arrangement preferred by manufacturers of HVAC&R equipment 'sized to specification', because it offers the best flexibility while matching the aerodynamic performance and speed, of the fan, and the available power and speed, of the motor, to the specified duty.

The use of the belt drive is mostly a heritage of the time when electronic VSD were unavailable, unaffordable or unreliable.

This is the only type of 'not complete assembly' that is, to some extent, dealt with inside the existing 'EU Fan Regulation' 327/11/EC. Its dealing is questionable, because in the attempt to allow rating the efficiency of these fans with reference to the ratio of the useful air power output to the electrical power input, it requires the estimate of the efficiency of the final, complete assembly using assumed efficiency of the parts. These are not existing at the time of the first sale. This also introduces additional safety-margins in the calculation, by mandating the minimum efficiency of legally sellable components such as motors.

This approach is creating an uneven market between products potentially intended for the same application, comparing direct-driven fans, which are measured as a complete assembly, with 'bare-shaft fans'. Their efficiency is estimated assuming the worst possible efficiency of the motor, and adding a further 0.9 reduction, as a measure for safety.

Moreover, if the 'placement on the market' happens when the operating, final, complete assembly is sold to its user or installer, this tortuous approach is essentially useless. When the fan is put in operation it must have been completed with a motor and a mechanical drive connecting it to the fan.

There is no need at all to assume anything on the motor efficiency, which must be known, and the only remaining issue is whether the belt-drive efficiency may be always measured, or must be estimated, and using which kind of computation model.

Another widely diffused type is usually known as 'motorized impeller'.

This may be a 'backward-curved impeller', designed for use without scroll, provided with a drive motor, most frequently of the external motor type. Very often, this item is manufactured by specialist firms, but sold without the inlet nozzle, which is built by the 'integrator' inside the machine where the fan is incorporated. This nozzle may have a significant impact on the efficiency of the assembly, between different designs.

Another example is the propeller-fan motorized impeller ('propeller fan' is an axial fan specifically designed for high-volume, low-pressure operation) or a motor combined or integrated with the blades of an axial fan, to be integrated into an inlet nozzle, acting also as a short fan case.

The nozzle is often provided by the 'integrator', being built into the panels of the machine into which the fans are incorporated. Sometimes also the structure supporting the impeller and motor in their operating position is provided by the integrator. The design of the nozzle and of the supporting brackets may impact the efficiency of the final, complete assembly significantly.

An additional example of 'motorized impeller' is the assembly of a forward-curved impeller with an external-rotor motor, to be completed with a suitable scroll case, acting as a diffuser. The scroll may be provided by the integrator, sometimes to better match it, in dimensions and/or shape, to the overall arrangement of the machine incorporating the fan. Here, different scroll design may change the efficiency of the final assembly by as much as 50% (of the rated efficiency).

A third common type of not-complete assembly is the assembly of an impeller and a matching case, still needing an integrated motor, which should drive and support the impeller, but which is not included in the scope of delivery.

This can be sold under the name of 'partly knocked-down, un-complete fan'. It allows manufacture of a direct-driven fan using a motor of choice of the integrator.

Impellers only.

Specialist manufacturers are providing the market with impellers only, either centrifugal impellers (designed for use inside scroll cases or for use without scroll as 'plug fans') or axial impellers, allowing smaller manufacturers to produce complete fans without involving themselves into the extensive investment, which is most frequently necessary in the manufacture of high-technology impellers.

All these kinds of not complete assemblies are necessarily going to be converted into a complete assembly, before being placed on the market or put in operation. The missing parts must be chosen and installed, otherwise the assembly cannot be operated at all. These additional parts may sometimes be highly integrated in the structure of the machine where the fan is being incorporated.

## Annex

---

At Eurovent, we are constantly advocating a level-playing for the entire HVAC&R industry taking into account views ranging from SMEs to large manufacturers, which all receive one vote within an Issue or Product Group meeting.

Consequently, as we also value an internal level-playing field, this ANNEX allows for positions that have not found a majority to find its place as well:

### Alternative position on 'not complete assemblies'

Fans integrated into other products may be built up using non-complete assemblies (e.g. impellers, motorised impellers, as well as impeller and scroll assemblies). In this case, the Declaration of Conformity of the complete incorporated fan may refer to the performance achieved by some non-complete assemblies, as tested or calculated by the original manufacturer of the non-complete assembly, using a nominal set of 'missing essential parts', not on the efficiency of the fan completed with parts of other design or characteristics.

The calculated efficiency may be based on the efficiency of the actual motor used at its actual load when driving the fan at its best efficiency duty point.

## About Eurovent

Eurovent, the European Committee of HVAC&R Manufacturers, is the representative of Europe's major national associations in the industry of heating, ventilation, air conditioning and refrigeration. Based on objective and verifiable data, its 19 members from 17 European states represent 1.010 companies, the majority small and medium-sized. In 2013, these accounted for a combined annual turnover of around 21 billion euros and employed more than 120.000 people – making Eurovent one of the largest industry committees of its kind.

Eurovent's roots date back to 1958. Over the years, the Brussels-based umbrella association has become a well-respected and known stakeholder that builds bridges between companies it represents, legislators and standardisation bodies on a EU and international level. The association favours a level-playing field for the entire industry and strongly supports energy-efficient and environmental-friendly solutions. Eurovent holds in-depth relations with partner associations around the globe. It is a founding member of the ICARHMA network, supporter of REHVA and contributor to the EU's BUILD UP initiative.

## Members of Eurovent



**Members:** AEFYT (Spain), AFEC (Spain), AGORIA (Belgium), ANIMA / CO.AER (Italy), APIC (Russia), Cluster HVAC (Slovenia), Dansk Ventilation (Denmark), FAMBSI (Finland), ISKID (Turkey), NKI (Netherlands), Svensk Ventilation (Sweden), Uniclimate (France), VDMA (Germany), VKE (Norway), VLA (Netherlands).

**Corresponding members:** 2VV (Czech Republic), Hauser (Austria), Hoval (Liechtenstein), Nationwide Filter Company (United Kingdom).

**Subunits:** Eurovent Certita Certification and Eurovent Market Intelligence (Paris, France).